

## Bombas de engranajes Caproni para aplicaciones móviles y agrícolas

Una relación entre la dirección de rotación y el lugar de los puertos de entrada y salida de las bombas.

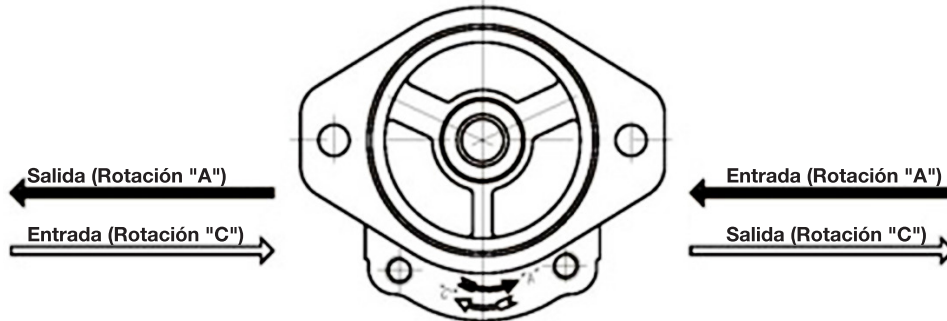

Grupo	Rotación	Código de desplazamiento	Eje de accionamiento	Código de la bomba	Conexiones
00 10 20 30 40					- Una brida con hilos métricos P4 - Una brida con hilos UNC M - Métrico G - Gas U - SAE J475
A	Izquierda				*** (*)
C	Derecha				X - A través de la tapa delantera Y - A través de las dos tapas
R	Bi-direccional				

Grupo 00		Grupo 10		Grupo 20		Grupo 20H		Grupo 30		Grupo 40	
Código	cm <sup>3</sup>	Código	cm <sup>3</sup>	Código	cm <sup>3</sup>	Código	cm <sup>3</sup>	Código	cm <sup>3</sup>	Código	cm <sup>3</sup>
0,25	0,25	1	1	4,5	4,5	15	15	20	20	36	36
0,3	0,3	1,25	1,25	6,3	6,3	16	16	22,5	22,5	42	42
0,5	0,5	1,6	1,6	7*	7*	19	19	25	25	46	46
0,75	0,75	2	2	8,2	8,2	22	22	28	28	50	50
1	1	2,5	2,5	10	10	25	25	32	32	55	55
1,25	1,25	2,65*	2,65*	11	11	28	28	36	36	60	60
1,5	1,5	3,15	3,15	12	12	32	32	42	42		
1,75	1,75	3,65	3,65	14	14	36	36	46	46		
2	2	4,2	4,2	15	15			50	50		
		4,7*	4,7*	16	16			55	55		
		5	5	17*	17*			60	60		
		5,7	5,7	19	19						
		6,1	6,1	22	22						
		7,4	7,4	25	25						
		8*	8*	28	28						
		8,5	8,5	32	32						
		9,8	9,8	36	36						

Ejemplo:  
20A14X073 - Bomba hidráulica de engranajes, grupo 20, sentido de rotación - en sentido antihorario, desplazamiento 14 cm<sup>3</sup>, modificación 073.



## Bombas a engranajes, Serie 30 de 20 a 60 cc/rev

q cm <sup>3</sup> /rev		20	22.5	25	32	36	42	46	50	55	60
p <sub>nom</sub>	bar	250	250	250	250	250	230	230	200	200	
n <sub>min</sub>	min <sup>-1</sup>	650	650	650	650	650	650	650	650	650	
n <sub>nom</sub>	min <sup>-1</sup>	1500	1500	1500	1500	1500	1500	1500	1500	1500	
n <sub>max</sub>	min <sup>-1</sup>	2500	2500	2500	2500	2300	2300	2100	2100	1750	
η <sub>qmin</sub>	%	80	80	82	83	83	84	84	85	85	
η <sub>min</sub>	%	73	73	74	75	76	76	77	78	78	
η <sub>qnom</sub>	%	94	94	94	94	94	95	95	95	95	
η <sub>nom</sub>	%	85	85	86	86	86	85	85	85	85	
η <sub>qmax</sub>	%	93	93	93	94	94	94	94	94	94	
η <sub>max</sub>	%	83	83	84	84	84	84	83	83	83	
p <sub>nom</sub>	kW	13.5	15.3	16.8	22.5	25	27.5	30	28	33	
p <sub>max</sub>	kW	23	26	28	36	38	41.5	41	44.5	38	

### Símbolos usados:

q	cilindrada por revolución.
p <sub>nom</sub>	presión nominal
n <sub>min</sub>	RPM mínimas
n <sub>nom</sub>	RPM nominal
n <sub>max</sub>	RPM máxima
p <sub>nom</sub>	Potencia consumida nom. a p <sub>nom</sub> y n <sub>nom</sub>
p <sub>max</sub>	Potencia consumida máx. a p <sub>nom</sub> y n <sub>máx</sub>

### Rendimiento volumétrico:

η <sub>qmin</sub>	a RPM mínima
η <sub>qnom</sub>	a RPM nominal
η <sub>qmax</sub>	a RPM máxima

### Rendimiento:

η <sub>min</sub>	a RPM mínimas
η <sub>nom</sub>	a RPM nominal
η <sub>máx</sub>	a RPM máxima

30A \_\_\_ X146H  
30C \_\_\_ X146H

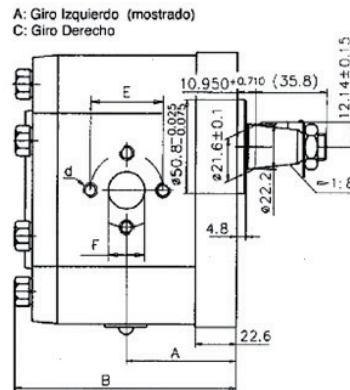
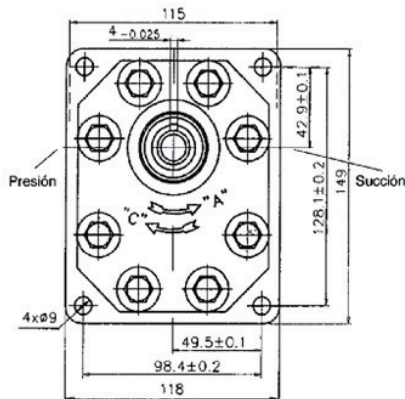

Tipo	Desplazamiento cm <sup>3</sup>	Dimensiones							
		A mm	B mm	Succión			Presión		
				E mm	d mm	F mm	E mm	d mm	F mm
30A(C)20x146H	20	54	112,3	40	M8	19	40	M8	19
30A(C)22,5x146H	22,5	53,3	110,9	40	M8	19	40	M8	19
30A(C)25x146H	25	54	112,3	40	M8	19	40	M8	19
30A(C)32x146H	32	62	128,3	51	M10	27	40	M8	19
30A(C)36x146H	36	63,5	131,4	51	M10	27	40	M8	19
30A(C)42x146H	42	66,3	137	51	M10	27	40	M8	19
30A(C)46x146H	46	68,2	140,8	51	M10	27	40	M8	19
30A(C)50x146H	50	70	144,4	51	M10	27	40	M8	19
30A(C)55x146H	55	72,2	148,9	51	M10	27	40	M8	19

30A X300  
30C X300

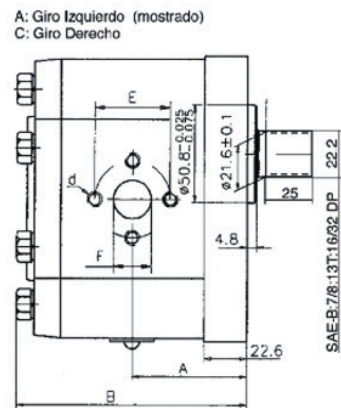
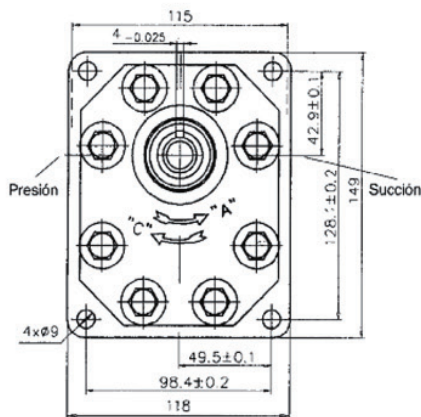

Tipo	Desplazamiento cm <sup>3</sup>	Dimensiones							
		A mm	B mm	Succión			Presión		
				E mm	d mm	F mm	E mm	d mm	F mm
30A(C)20x300	20	54	112,3	40	M8	19	40	M8	19
30A(C)22,5x300	22,5	53,3	110,9	40	M8	19	40	M8	19
30A(C)25x300	25	54	112,3	40	M8	19	40	M8	19
30A(C)32x300	32	62	128,3	51	M10	27	40	M8	19
30A(C)36x300	36	63,5	131,4	51	M10	27	40	M8	19
30A(C)42x300	42	66,3	137	51	M10	27	40	M8	19
30A(C)46x300	46	68,2	140,8	51	M10	27	40	M8	19
30A(C)50x300	50	70	144,4	51	M10	27	40	M8	19
30A(C)55x300	55	72,2	148,9	51	M10	27	40	M8	19

30A X169H  
30C X169H

\* designación: 30A (C) ... X169HE

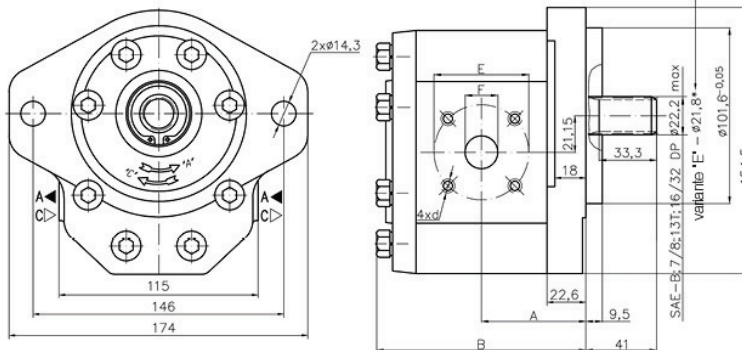

Tipo	Desplazamiento cm <sup>3</sup> /rev	Dimensiones							
		A mm	B mm	Entrada			Salida		
				E mm	d mm	F mm	E mm	d mm	F mm
30A(C)20x169H	20	56,1	116,7	40	M8	19	40	M8	19
30A(C)22,2x169H	22,5	57,6	119,7						
30A(C)25x169H	25	58,3	121,1						
30A(C)28x169H	28	60,2	124,7						
30A(C)28x169HH	28	64,7	133,7						
30A(C)32x169	32	62,0	128,3	55	M8	27	55	M8	19
30A(C)32x169H	32	66,5	137,3						
30A(C)36x169	36	63,5	131,4						
30A(C)36x169H	36	68,0	140,5						
30A(C)42x169	42	66,3	137,0						
30A(C)42x169H	42	70,8	146,1						
30A(C)46x169H	46	72,7	149,8						
30A(C)50x169H	50	74,5	153,4						
30A(C)55x169H	55	76,7	157,9						
30A(C)60x169H	60	78,7	162,4						

**30A X333 V**

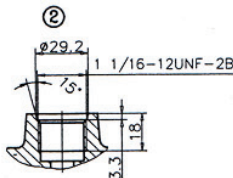
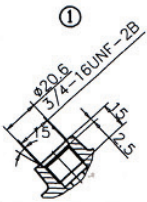
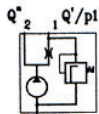
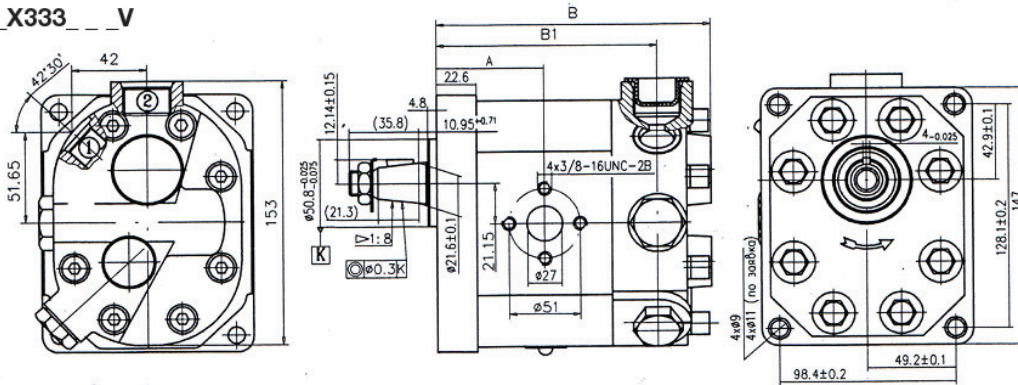

Tipo	Desplazamiento cm <sup>3</sup>	Tipo de válvula								B	B1	A
		10/7V		24/15V		25/11V		28/10V				
		Q'	P1	Q'	P1	Q'	P1	Q'	P1			
30A25X333H-.../...V	25									149,6	119,6	58,4
30A32X333H-.../...V	32									165,8	135,8	66,4
30A36X333H-.../...V	36									169	139	68,1
30A42X333H-.../...V	42	8 <sup>+</sup>	70 <sup>+</sup>	12 <sup>+</sup>	80 <sup>+</sup>	25 <sup>+</sup>	110 <sup>+</sup>	28 <sup>+</sup>	100 <sup>+</sup>	174,6	144,6	70,8
30A46X333H-.../...V	46									178,3	148,3	72,7
30A50X333H-.../...V	50									181,9	151,9	74,5
30A55X333H-.../...V	55									186,4	156,4	76,7

**30A X357H VW  
30C X357H VW**  
Tapa divisoria de caudal

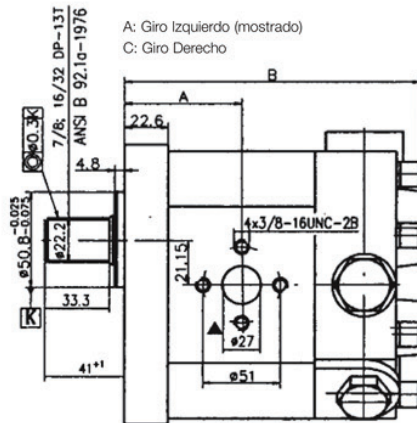
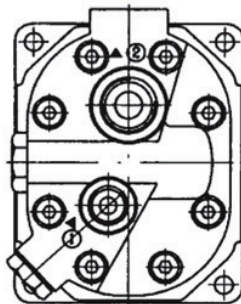

A: Giro Izquierdo (mostrado)  
C: Giro Derecho

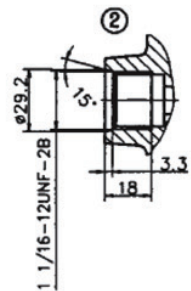
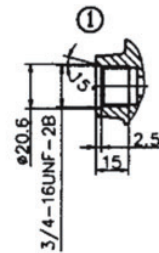
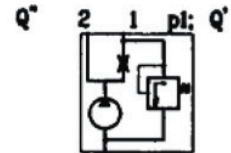

Tipo	Desplazamiento cm <sup>3</sup>	Dimensiones							
		A mm	B mm	Válvulas					
				12/8V		25/11V		28/10V	
				p1 bar	Q l/min	p1 bar	Q l/min	p1 bar	Q l/min
30A36x357H-.../...VW	36	68	169						
30A42x357H-.../...VW	42	70.8	174.6						
30A46x357H-.../...VW	46	72.7	178.3	80 <sup>+</sup>	12 <sup>+</sup>	110 <sup>+</sup>	25 <sup>+</sup>	100 <sup>+</sup>	28 <sup>+</sup>
30A50x357H-.../...VW	50	74.5	181.9						
30A55x357H-.../...VW	55	76.7	186.4						

30A \_\_ X236  
30C \_\_ X236

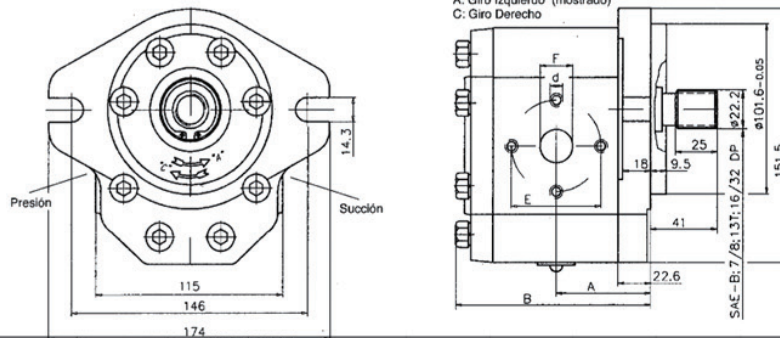

Tipo	Desplazamiento cm <sup>3</sup>	Dimensiones							
		A mm	B mm	Succión			Presión		
				E	d mm	F	E	d mm	F
30A(C)20x236	20	54	112,3	40	M8	19	40	M8	19
30A(C)22,5x236	22,5	53,3	110,9	40	M8	19	40	M8	19
30A(C)25x236	25	54	112,3	40	M8	19	40	M8	19
30A(C)32x236	32	62	128,3	51	M10	27	40	M8	19
30A(C)36x236	36	63,5	131,4	51	M10	27	40	M8	19
30A(C)42x236	42	66,3	137	51	M10	27	40	M8	19
30A(C)46x236	46	68,2	140,8	51	M10	27	40	M8	19
30A(C)50x236	50	70	144,4	51	M10	27	40	M8	19
30A(C)55x236	55	72,2	148,9	51	M10	27	40	M8	19

30A \_\_ X237  
30C \_\_ X237

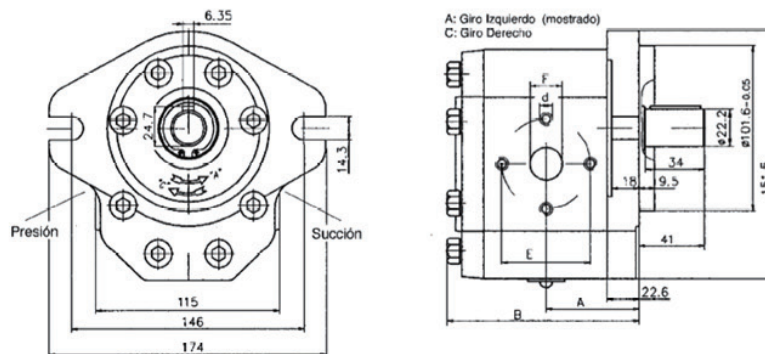

Tipo	Desplazamiento cm <sup>3</sup>	Dimensiones							
		A mm	B mm	Succión			Presión		
				E	d mm	F	E	d mm	F
30A(C)20x237	20	54	112,3	40	M8	19	40	M8	19
30A(C)22,5x237	22,5	53,3	110,9	40	M8	19	40	M8	19
30A(C)25x237	25	54	112,3	40	M8	19	40	M8	19
30A(C)32x237	32	62	128,3	51	M10	27	40	M8	19
30A(C)36x237	36	63,5	131,4	51	M10	27	40	M8	19
30A(C)42x237	42	66,3	137	51	M10	27	40	M8	19
30A(C)46x237	46	68,2	140,8	51	M10	27	40	M8	19
30A(C)50x237	50	70	144,4	51	M10	27	40	M8	19
30A(C)55x237	55	72,2	148,9	51	M10	27	40	M8	19

30C X335 VW  
Tapa trasera divisora de caudal

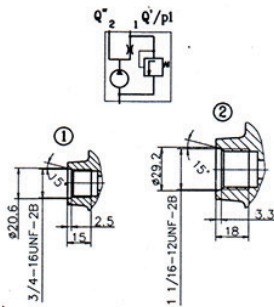
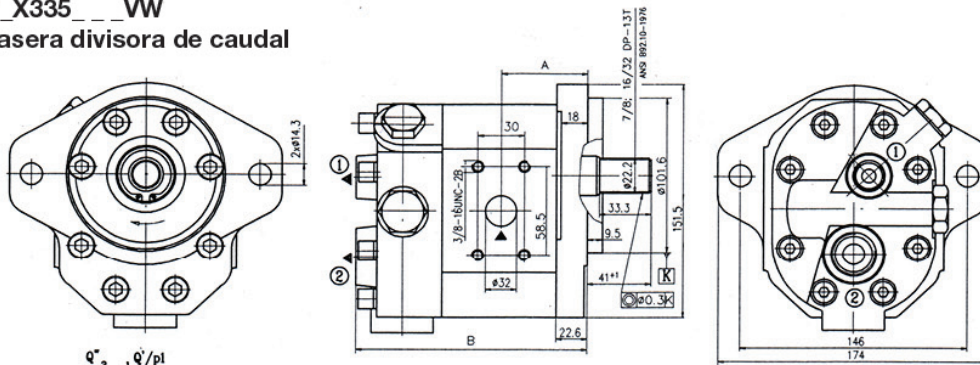

Tipo	Desplazamiento cm <sup>3</sup>	Tipo de válvula								B mm	A mm
		10/7V		24/15V		25/11V		28/10V			
		Q'	P1	Q'	P1	Q'	P1	Q'	P1		
30A36X335H-.../...VW	36	12+1	80+5	25+1	110+5	28+1	100+5			169	68,1
30A42X335H-.../...VW	42									174,6	70,8
30A46X335H-.../...VW	46									178,3	72,7
30A50X335H-.../...VW	50									181,9	74,5
30A55X335H-.../...VW	55									186,4	76,7

30A X383HVU  
30C X383HVU

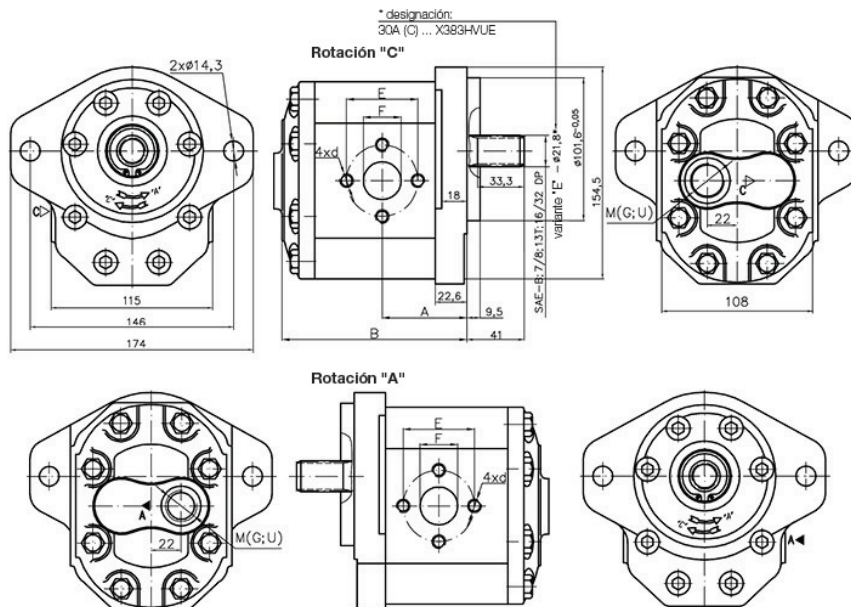

Tipo	Desplazamiento cm <sup>3</sup>	Dimensiones							
		A mm	B mm	Succión			Presión		
				E	d	F	M	G	U
30A(C)20X383HVU	20	56,1	114,7	40	5/16-18UNC	19	1 1/16"-12UNF-2B		
30A(C)22,2X383HVU	22,5	57,6	117,7						
30A(C)25X383HVU	25	58,3	119,1						
30A(C)28X383HVU	28	60,2	122,7						
30A(C)32X383VU	32	62,0	126,3						
30A(C)32X383HVU	32	66,5	135,3						
30A(C)36X383VU	36	63,5	129,4						
30A(C)36X383HVU	36	68,0	138,5						
30A(C)42X383VU	42	66,3	135,0						
30A(C)42X383HVU	42	70,8	144,0						
30A(C)46X383HVU	46	72,7	147,8						
30A(C)50X383HVU	50	74,5	151,4						
30A(C)55X383HVU	55	76,7	155,9						
30A(C)60X383HVU	60	78,7	160,4	51	3/8-16UNC-2B	27			

30A \_\_ X420HV2

30C \_\_ X420HV2

Bomba para toma de fuerza con Válvula

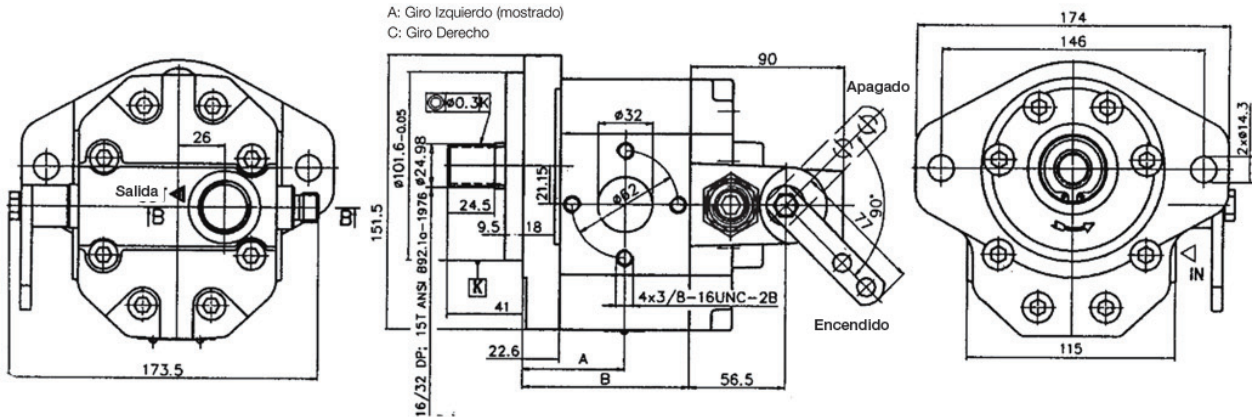

A: Giro Izquierdo (mostrado)  
C: Giro Derecho

Tipo	Desplazamiento cm <sup>3</sup>	Dimensiones	
		A mm	B mm
30A32x420HV2	32	66.5	110.3
30A36x420HV2	36	68	113.5
30A42x420HV2	42	70.8	119.3
30A46x420HV2	46	72.7	122.8
30A50x420HV2	50	74.5	126.4
30A55x420HV2	55	76.7	130.9
30A60x420HV2	60	78.7	135.4

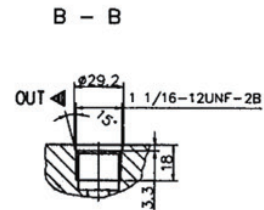
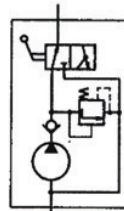

30S(D) \_\_ X165W

Bomba para toma de fuerza

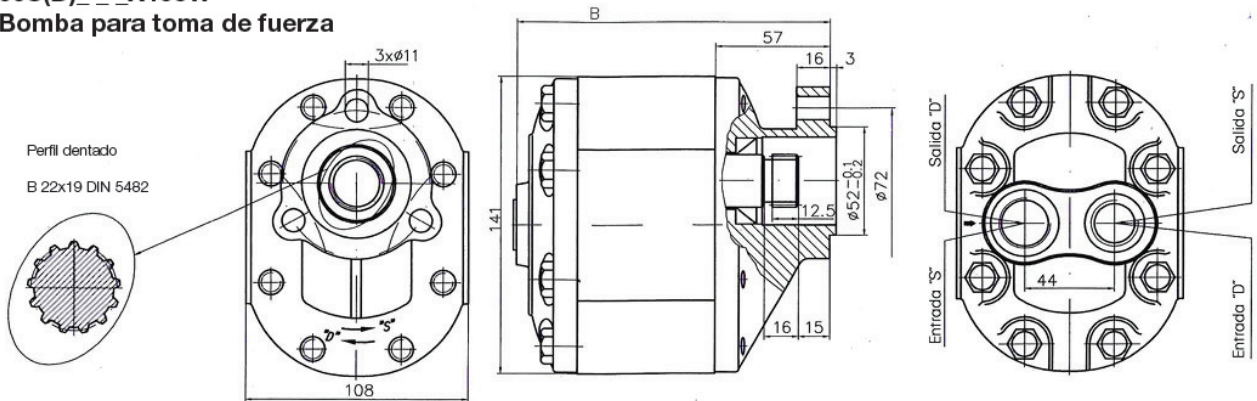

Tipo	Desplazamiento	B mm	Entrada G	Salida G	p bar	Velocidad 1/s
	cm <sup>3</sup>					
30A(C)20X165HW	20	156	G 1	G 3/4	200	500 ... 2500
30A(C)22,5X165HW	22,5	159,1	G 1	G 3/4	200	500 ... 2500
30A(C)25X165HW	25	160,5	G 1	G 3/4	200	500 ... 2500
30A(C)28X165HW	28	164,1	G 1	G 3/4	200	500 ... 2500
30A(C)32X165W	32	167,7	G 1	G 3/4	200	500 ... 2500
30A(C)32X165HW	32	176,7	G 1	G 3/4	200	500 ... 2500
30A(C)36X165W	36	170,8	G 1	G 3/4	190	500 ... 2300
30A(C)36X165HW	36	179,7	G 1	G 3/4	190	500 ... 2300
30A(C)42X165HW	42	166,2	G 1	G 3/4	190	500 ... 2300
30A(C)42X165HW	42	176,2	G 1	G 3/4	190	500 ... 2300
30A(C)46X165HW	46	189,6	G 1	G 3/4	175	500 ... 2100
30A(C)50X165HW	50	192,7	G 1	G 3/4	175	500 ... 2100
30A(C)55X165HW	55	197,9	G 1	G 3/4	160	500 ... 1750
30A(C)60X165HW	60	201,7	G 1	G 3/4	150	500 ... 1750